



User Manual

24 Ports Gigabit Ethernet Switch
(1U Rack Mounted)
ST-G24TR

Packing List

- Ethernet Switch
- User Manual
- Power Cable
- Bracket kits

Product description

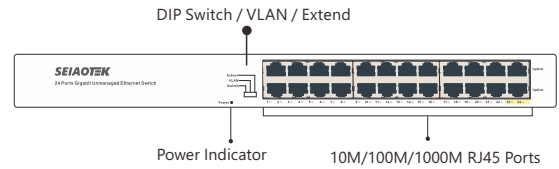

Indicator light	Status	Description
PWR	ON	Switch power supply is normal
	OFF	The switch is not powered on or the power supply is abnormal
Link/Act	ON	Port is connected
	Flashing	Port is transmitting data
	OFF	The port is not connected, or the connection is abnormal

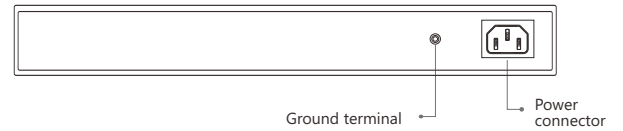

Interface/button	Description
Rj45 Ports	24 Ports Gigabit Ethernet Rj45, Supporting Auto-MDI/MDIX function.
Ground terminal	Connect the protective ground wire to prevent lightning strikes.
Power connector	Connect the power cable with the switch.
DIP Switch VLAN Extend	Default Mode, switch all ports can communicate with each other
	Enable VLAN, and the access ports isolated from each other and only can communicate with uplink port.
	Switch to Extend, Port 1~24 rate down to 10M, the maximum transmission distance reach upto 250m.

Device Installation

Installation Precautions

To avoid damage to the switch or personal injury caused by improper use, please follow up the below precautions:

1. During the installation procedure, wear an anti-static wristband, keep the switch powered off. Ensure that the input voltage under the input voltage range.
2. Ensure that the heat dissipation holes of the switch are well ventilated.
3. Do not disassemble the switch.
4. Do not supply power to the switch before cleaning it. Do not use any liquid to scrub the switch.
5. Keep the switch far away from power lines, lights, and power grids.

Note

A tamper-evident seal is sealed on a mounting screw of the switch chassis. When the agent maintains the switch, the maintenance switch is required. The seal remains intact. If the user needs to open the switch case, please obtain the permission of the local agent. Otherwise, due to all consequences caused by opening the cabinet will be borne by the user himself.

Prepare the installation tools

1. Static bracelet
2. Screw driver
3. Optional: flat-blade screw driver, needle-nose pliers, diagonal pliers

Install the switch into a 19-inch standard cabinet

Step 1: Check the grounding and stability of the rack-mountable.

Step 2: Use the screws to fix the two L-shaped brackets on both sides of the switch.

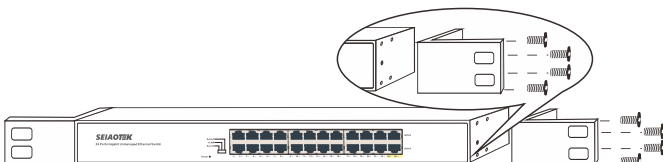

Step 3: Place the switch in a proper position in the rack, and fix the L-shaped brackets on the guide grooves at both ends of the rack with screws (if users required) to ensure that the switch is installed on the rack smoothly

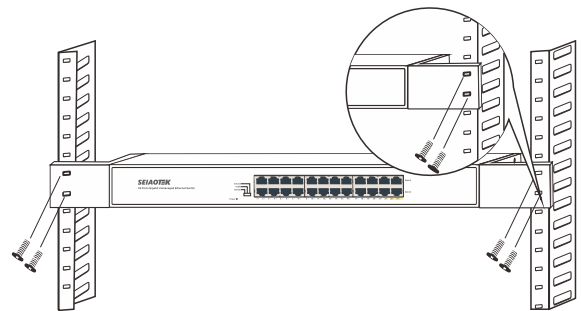

Install the switch to the desktop

After sticking the foot pads on the four corners of the bottom surface of the switch, please place and keep the switch face up on the stable desktop.

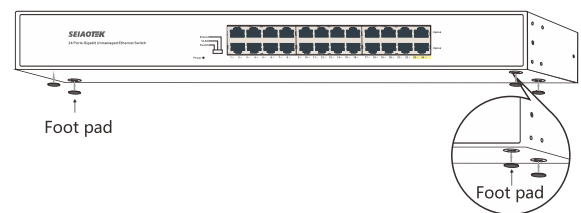

Hardware connection

Connect Rj45 port

Connect one end of the network cable to the Rj45 port of the switch, and the other end to the Rj45 Ethernet port of the opposite network device.

- Step 1:** Connect one end of the ground wire to the ground terminal of the switch
- Step 2:** Connect the other end of the ground wire to other equipment that has been grounded or directly connect it to the ground bar of the equipment room engineering terminal.

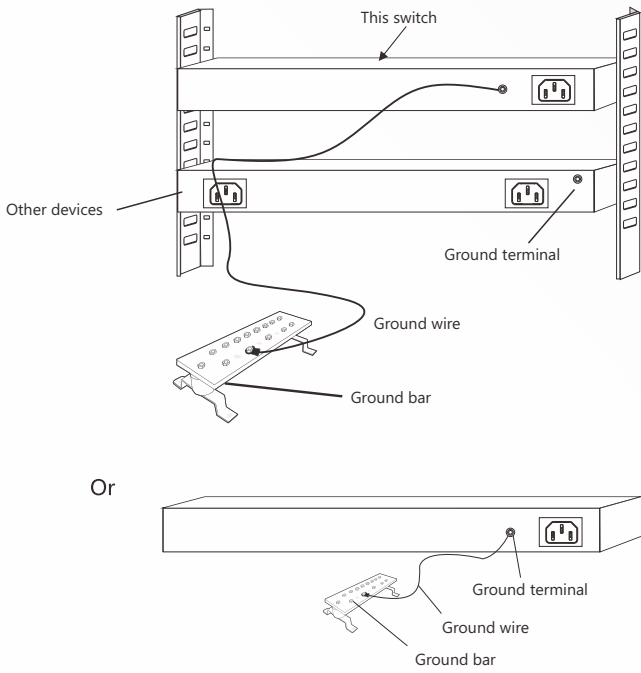

Or



Note
The ground wire of the switch should be connected to the engineering ground of the equipment room. The grounding fire water pipe and the lightning rod of building are not properly grounded.

Specifications

Name	24 Ports Gigabit Ethernet Switch (1 U Rack-Mounted)	
Model	ST-G24TR	
Interface	Rj45 ports	10M/100M/1000M Rj45 Ports
LED	PWR, Link, Act	
Processing Types	Store-and-forward	
	Half duplex back pressure and IEEE802.3x full duplex flow control	
Performance Specification	Bandwidth	48Gbps
	Packet Forwarding Rate	35.71Mpps
	MAC Address	8K
Network Standards	IEEE802.3i 10BASE-T IEEE802.3u 100BASE-TX IEEE802.3ab 1000BASE-T IEEE802.3x Flow Control IEEE802.3az EEE	
Power Input	AC 100~240V 50~60Hz	
Dimension	440mm (L) x 220mm (W) x 44mm (H)	
Cables	UTP Cat 5 or above	
Environment Specification	Working Temperature: 0°C ~ 45°C, Humidity: 10% ~ 90% RH non-condensing	
	Storage Temperature: 20°C ~ 70°C, Humidity: 5% ~ 95% RH non-condensing	

Warranty Card

Model NO.	
Serial NO.	
Purchase Date	
RMA Number	
Return Reason	
Customer Name	
Customer Address	
Customer Email	

Note: Please refer to the User Manual for Detail Warranty policy